

The Atlas Copco logo is displayed in white text within a blue rectangular box in the top right corner of the image. The background of the entire image is a large-scale industrial construction site at dusk or dawn, featuring a massive yellow crane, a white pickup truck, and a yellow HiLight V5+ light tower illuminating a large pile of earth and gravel. A technical drawing overlay is visible in the bottom left corner.

HiLight V5+ Making sites brighter and safer

CPCB II compliant LED light tower
with HardHat® canopy

Made in India

"Most eco-friendly light tower in India"

HiLight V5+ Safe Light

The HiLight V5+ are the light towers that construction sites, outdoor events and industries around the world have been asking for. These light towers offer the ultimate in fuel economy and reliability. Its LED lighting technology provides extended benefits and represents outstanding value for our customers.

The HiLight V5+ include a HardHat® canopy as standard, which ensures maximum protection of internal parts. This range of light towers is perfect for multiple drop rental applications and providing users a robust and easy-to-transport set of lighting options that match any site requirements. The extended safety features also guarantee the protection of bulbs during transportation.

Innovative LED lights

- Unique lens design having a uniform light distribution.
- Right combination of LED chips and LED optics.
- Directional optics are made of glass fibre which offers uniform light distribution.
- Each LED lamp has one concave and one convex lens to ensure even light distribution.
- LED lamps have an aluminium casting which offers heavy duty protection and robustness under intensive use.
- Each LED lamp can withstand baseball impact thrown at a speed of 100MPH



Robust and durable

Legendary HardHat® enclosure made of Polyethylene. The exclusive hinged top panel provides easy access to the engine, generator and electrical components for quick and hassle-free maintenance.

Optional features

- Controller
- Battery switch
- RCCB
- Mains
- Fire extinguisher
- Cold start*
- Photocell*
- Electric winch*

*works only with controller

QUIET OPERATION

75 dB(A)



as per CPCB II

ADDITIONAL FEATURES

HardHat®



IP PROTECTION

Heavy duty lights with IP 67 protection



LAMP DURABILITY / LIFE EXPECTANCY

LED, MORE THAN
30,000 Hrs



FUEL CONSUMPTION

0.9 l/h



LIGHT COVERAGE M² (Average 20 luxes)

5,000



High luminosity

The HiLight V5+ comes with 4 LED lamps x 350 W that gives you even more durability and light coverage.

LED Light

Fuel efficiency

The best fuel consumption in its segment with a fuel consumption of 0.9 l/hr, and a maximum run time of 88 hrs.



SAVINGS:
• UP TO **50%**
• 1,000 LITERS
EVERY 2,000 HOURS

Safe mast

The vertical mast is extremely stable and quick to operate. This model can be transported with the mast in vertical position.

EXTRA SAFETY FEATURES

Manual vertical mast



Lifting hooks

Quiet operation

Thanks to its air flow design and the Hardhat® canopy, the HiLight V5+ is the most silent Light Tower in its segment with 75 dB(A) as per CPCB II

Fork lift slots

Emergency switch

Detachable, foldable and retractable tow bar



Technical Data

		HiLight V5+	
Performance Data			
Rated Frequency	Hz	50	
Rated Voltage	VAC	230	
Rated Power (PRP)	kW	5	
MX Sound Power level (LWA) (measured according to CPCB II)	dB(A)	75	
Engine			
Model	Lombardini KD441-GSI2		
Rated Net Output (PRP)	kW	6.1	
Alternator			
Model	Sincro		
Rated output	kVA	4.8	
Degree of protection	IP	IP 23	
Consumption			
Fuel tank capacity	litre	80	
Runtime with lamps ON	hrs	88	
Lights			
Floodlights	LED		
Wattage	W	4 x 350	
Mast			
Type	Manual vertical, 5 section		
Rotation	degrees	360	
Maximum Height	m	7.5	
Dimensions and weight			
Dimensions in transport with tilted towbar (LxWxH)	m	1.95 x 1.10 x 2.50	
Weight (dry)	kg	700	

Light coverage m ²	5,000 (average 20 luxes)		
Lamps	LED		
Mast	Vertical Manual		
Features	HardHat [®] canopy		

Photos and illustrations contained herein might depict products with optional and/or extra components which are not included with the standard version of the product and, therefore, are not included in a purchase of such product unless the customer specifically purchases such optional/extra components. We reserve the right to change the specifications and design of products described in this literature without notice. Not all products are available in all markets.

Contact:

S Kumar: +91 99406 86506, s.kumar@atlascopco.com
 Prakash Khobragade: +91 93314 11141, prakash.khobragade@atlascopco.com
 Fenil Shah: +91 70304 64386, fenil.shah@atlascopco.com

Additional Standard Features

- 4 LED lamps x 350 W
- Directional optics with glass fibre
- LED lamps with one concave and one convex lens
- LED lamps with aluminium casting
- 4 heavy duty stabilizers with level bubble
- Oil drains for serviceability
- User friendly control & power panel:
 - Independent circuit breakers
 - Hour meter & key switch
- 80 liter fuel tank for long run time between fills
- Emergency stop button
- Auxiliary power socket of 10A with safety feature of dedicated MCB
- Power selection switch for lights or auxiliary power

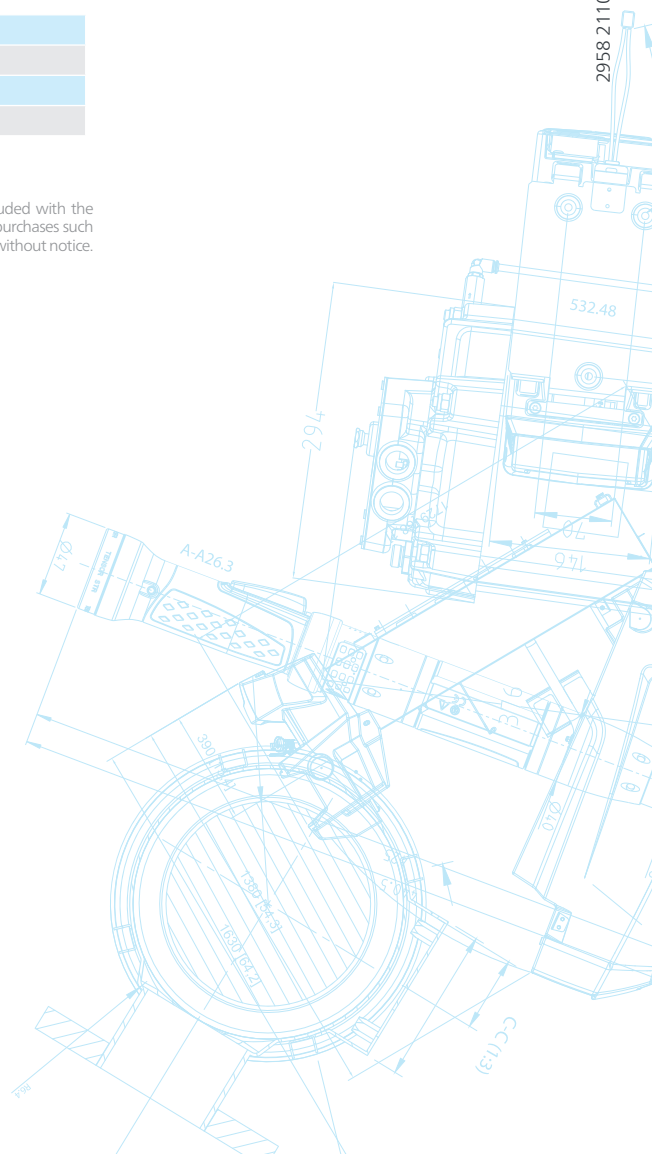

Atlas Copco India Ltd.

Reach us: cr.india@atlascopco.com
 Toll free number: 1800 120 110030
atlascopco.com/en-in